

SOCKS PACKAGING

AUTOMATIC HORIZONTAL FLOWPACK BAGGING UNIT SUITABLE FOR
A WIDE RANGE OF PRODUCTS

FLOWPACK

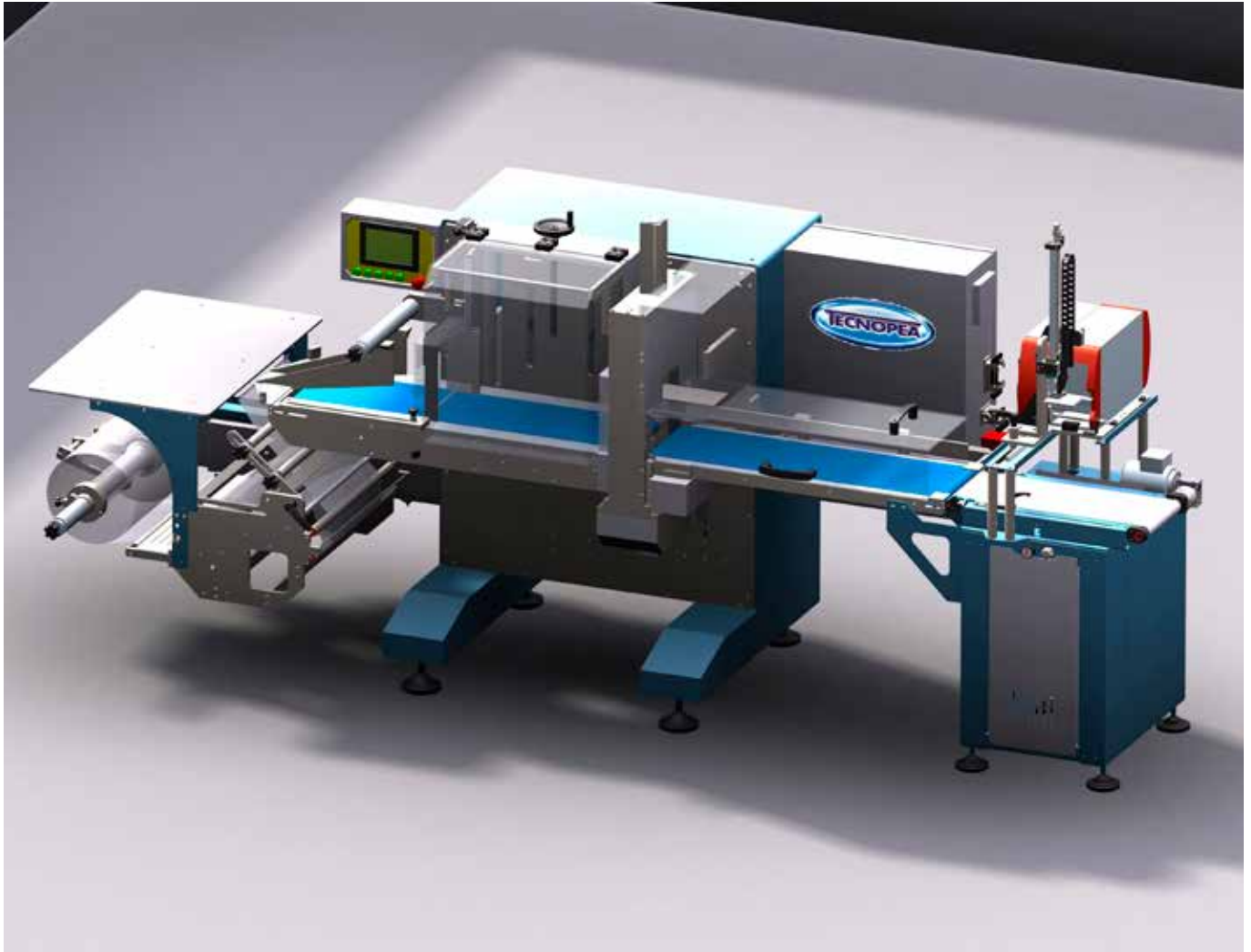

SOCKS BOARDING FLOWPACK

This bagging machine can be connected to an automatic line or manually fed and it has the following features:

- Manual loading of products on the feeding conveyer
- Connecting belt for the automatic feeding (optional)
- Creating bags from a film on a roll
- Translating sealing system
- PLC for the electronic control of all main functions;
- Touch screen display for the machine setting
- Automatic print and apply option for labels

SOCKS BOARDING FLOWPACK

Specifications	Values
Air pressure	6 bar
Air consumption	13,5 m ³ /hr
Installed power	3,5 kW
Absorbed power	1,8 kW
Max. Proctivity	Up to 18 bags/min
Max film width	600 mm
Max sealing length	300 mm

Features
High productivity
Very easy to use
Versatility

SOCKS BOARDING FLOWPACK

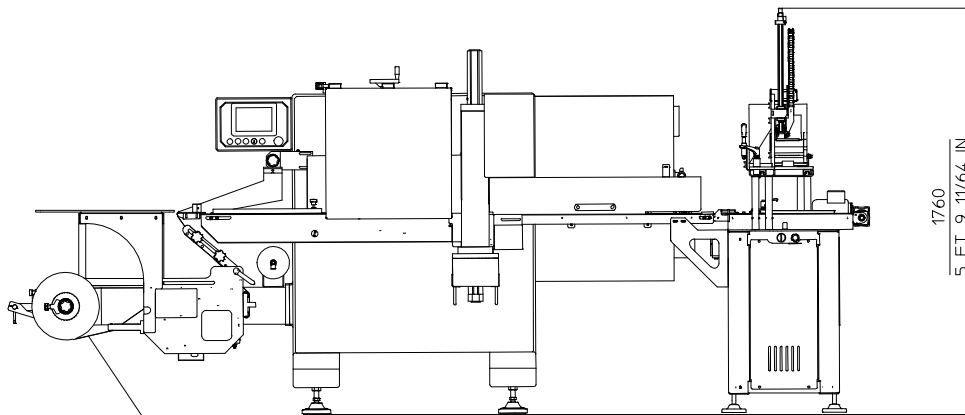

**ROLL
FILM FEEDER**

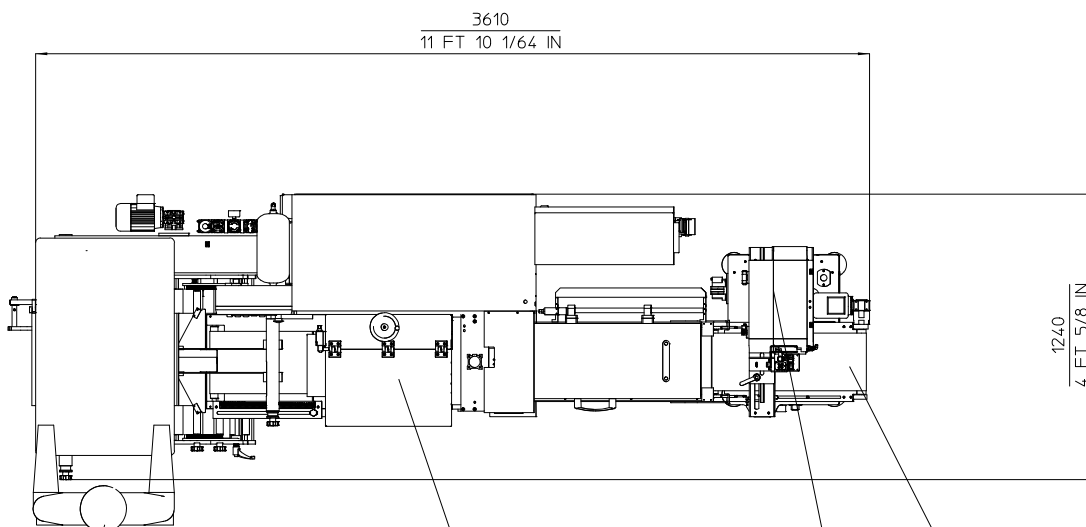

OPERATOR

BAGGING UNIT

LABELER UNIT

UNLOADING

TECNOPEA



TECNOPEA S.R.L.

Via Don Eridano Torri, 2

25027 Quinzano d'Oglio, Brescia - Italy

Tel.: +39 030 992 3780 - Fax: +39 030 9923996

info@tecnopea.com - www.tecnopea.com